



EZY Chek Systems CERTIFICATION EXAM COVER SHEET

PLEASE CHECK ALL
METHODS THAT APPLY

- EZY 3 LOCATOR PLUS
- PRODUCT LINE TESTING
- LEAK DETECTOR TESTING

Contact Name: _____

Company Name: _____

Technician Name: _____

Company Address: _____

Company Phone: _____

Company Fax: _____

E-Mail Address _____

Technician SSN: _____

(Last 6 digits - ONLY!)

INITIAL

_____ I agree to completely and without deviation follow the protocol set forth by Estabrook's, Inc. regarding the procedures and practices instructed by and certified by Brad Estabrook when using the Estabrook's, Inc. EZY Chek Systems.

_____ I agree to follow Estabrook's, Inc. protocol regarding certification and calibration.

_____ I agree to renew my certification biannually; I understand that it is my responsibility to contact Estabrook's, Inc. to arrange my recertification prior to my certification expiration date.

_____ I agree to calibrate my equipment annually; I understand that "equipment" is defined as the Acoustic Signal Processor, In-Tank Microphone, Pressure Sensor, Water Sensor Display, Water Sensor Probe and Negative Pressure Gauge. I understand that it is my responsibility to contact Estabrook's, Inc. to arrange the annual calibration of my equipment prior to the expiration date.

_____ I have read the above requirements and agree to the terms and conditions there to.

Technician Signature

Date



EZY Chek Systems

EZY 3 LOCATOR PLUS

CERTIFICATION

===== **EXAM** =====

Read each question; write the letter to the answer you chose in the space provided next to the question number.

- 1) _____ What is the PSI (weight) of water?
 - a. .036
 - b. .032
 - c. .026
 - d. .033

- 2) _____ What is the PSI (weight) of gas?
 - a. .036
 - b. .032
 - c. .026
 - d. .033

- 3) _____ What is the PSI (weight) of diesel?
 - a. .036
 - b. .031
 - c. .026
 - d. .049

- 4) _____ What is the PSI (weight) of kerosene?
 - a. .033
 - b. .031
 - c. .028
 - d. .029

- 5) _____ What is the PSI (weight) of transmission fluid?
 - a. .036
 - b. .033
 - c. .049
 - d. .029

- 6) _____ What is the PSI (weight) of motor oil?
 - a. .036
 - b. .031
 - c. .022
 - d. .033

- 7) _____ What is the PSI (weight) of brine?
 - a. .049
 - b. .029
 - c. .028
 - d. .034

EZY Chek Systems
EZY 3 LOCATOR PLUS CERTIFICATION EXAM

- 8) _____ Tank capacity shall not exceed what size?
- 20,000 gallons
 - 30,000 gallons
 - 50,000 gallons
 - 100,000 gallons
- 9) _____ What is the “*maximum*” pressure place on the tank top and shall never be exceeded?
- 2.00 psi of vacuum
 - 4.00 psi of vacuum
 - 6.00 psi of vacuum
 - 8.00 psi of vacuum
- 10) _____ What is the “*minimum*” amount of ullage space required to conduct a test on a tank?
- 1% total tank volume -or- 50 gallons whichever is less
 - 2% total tank volume
 - 50 gallons
 - 1% total tank volume -or- 50 gallons, whichever is greater
- 11) _____ What is the “*maximum*” amount of ullage space required to conduct a test on a tank?
- 10,000 gallons
 - 20,000 gallons
 - 30,000 gallons
 - 99% total tank capacity
- 12) _____ Before pulling vacuum on a tank and running an acoustic test, the microphone should always be checked for proper operation?
- True
 - False
- 13) _____ After the tank is completely sealed off, what must be done “*before*” turning on the motor blower to pull vacuum on the tank?
- All safety precautions shall be made to area.
 - The calculation must be completed to determine vacuum that shall be applied to the tank.
 - A background base line test must be taken of the sound in the tank with no vacuum applied.
 - All of the above.
- 14) _____ At a “*minimum*”, how long should the motor blower run and circulate once the proper amount of vacuum has been applied to the tank?
- 1-2 minutes
 - 3-5 minutes
 - 5-7 minutes
 - 7-9 minutes
- 15) _____ At a “*minimum*”, how long must the technician run the acoustic portion of the test (*with the exception of Rockland County*)?
- 4 minutes
 - 1 minutes
 - 2 minutes
 - 3 minutes

EZY Chek Systems
EZY 3 LOCATOR PLUS CERTIFICATION EXAM

- 16) _____ If the acoustic equipment reveals a "hiss", what portion of the tank may be leaking?
- Below the liquid level
 - Above the liquid level
 - The tank interstitial space
 - It can only be a vent or stage II line that causes this
- 17) _____ If the acoustic equipment reveals a "bubble", what portion of the tank may be leaking?
- Below the liquid level
 - Above the liquid level
 - The tank interstitial space
 - It can only be a vent or stage II line that causes this
- 18) _____ If the acoustic equipment reveals "no" sound and there is no ground water around the tank, the tank is tight?
- True
 - False
- 19) _____ On the digital pressure sensor; where should the switches be set to monitor the tank's vacuum level?
- Slow/Fast and PSI
 - Slow/Fast and H₂O
 - Slow/Fast and HG
 - Slow/Fast and KPA
- 20) _____ calculate the following "minimum test length" for running a water intrusion test when your average calibration is **50mL** (round to the nearest minute):
- 12 minutes
 - 16 minutes
 - 24 minutes
 - 32 minutes
- 21) _____ calculate the following "minimum test length" for running a water intrusion test when your average calibration is **75mL** (round to the nearest minute):
- 12 minutes
 - 16 minutes
 - 24 minutes
 - 32 minutes
- 22) _____ calculate the following "minimum test length" for running a water intrusion test when your average calibration is **125mL** (round to the nearest minute):
- 30 minutes
 - 32 minutes
 - 40 minutes
 - 48 minutes
- 23) _____ calculate the following "minimum test length" for running a water intrusion test when your average calibration is **150mL** (round to the nearest minute):
- 30 minutes
 - 32 minutes
 - 40 minutes
 - 48 minutes

EZY Chek Systems
EZY 3 LOCATOR PLUS CERTIFICATION EXAM

- 24) _____ What is the leak threshold for water intrusion?
- a. .05 inches
 - b. 0 gallons
 - c. .0140 inches
 - d. .05 gallons
- 25) _____ If .0100 gallons of water did intrude into the tank during a test, does the tank pass or fail?
- a. Pass
 - b. Fail
- 26) _____ What is the “*minimum*” amount of calibrations that must be performed prior to setting your water intrusion sensor and conducting a water intrusion test?
- a. None
 - b. 1 calibration
 - c. 2 calibrations
 - d. 3 calibrations
- 27) _____ Estabrook’s recommends what test solution when calibrating your conductive water sensor?
- a. A water/antifreeze mix
 - b. A water/biocide mix
 - c. A antifreeze/biocide mix
 - d. Straight water
- 28) _____ It is critically important to accurately determine water table prior to conducting a tank tightness test?
- a. True
 - b. False
- 29) _____ All tank testing equipment is required to be calibrated annually by the manufacturer, Estabrook’s, Inc.?
- a. True
 - b. False
- 30) _____ How often shall a technician recertify with the manufacturer of the EZY 3 Locator Plus test equipment?
- a. Every 2 years
 - b. Every 4 years
 - c. Every 5 years
 - d. Certification does not need to be renewed

Data Sheet Instructions

On the following pages you will find three Estabrook's, Inc. EZY 3 Locator Plus Pressure Calculation Data Sheets.

We have provided you with the necessary information on the Data Sheet to complete the Pressure Calculations ***and*** the Calculation for the Test Period.

Product Information:

- ◆ Using the data provided in the "Product Type" located at the top left of the Pressure Calculation Sheet, enter the "WEIGHT OF PRODUCT" into the corresponding space provided in the Pressure Sensor Calculation box.
- ◆ Use this data to complete the Pressure Calculations along with the other Data provided.

Pressure Calculations:

- ◆ Data is provided on the Tank Diagram located on the bottom right of the Pressure Calculation Sheet.
- ◆ Enter this data into the corresponding space in the "PRESSURE SENSOR CALCULATION" box.
- ◆ Complete all calculations; 1-7 to achieve the "TEST PRESSURE".

Water Sensor Calibration:

- ◆ Data is provided in the "WATER SENSOR CALIBRATION" box located on the bottom left of the Pressure Calculation sheet.
- ◆ Average the three Water Sensor Calibrations and enter it in to the corresponding space marked "Average".
- ◆ Complete the "Calculations for Test Period" to achieve the "Time of Test".



PRESSURE CALCULATION & WATER SENSOR CALIBRATION

DATA SHEET

Test Date _____

MANUFACTURED BY: ESTABROOK'S INC. 1-877-368-7215

TOTAL TANK VOL.	
PRODUCT VOL.	
ULLAGE VOL.	
PRODUCT TYPE	DIESEL OR #2 OIL
PBS # (NEW YORK)	
TANK #	TEST #1

Location	
Address	
City/State/Zip	
Location Contact	
Location Phone	
Depth of Groundwater Determined:	
By:	
Where:	

PRESSURE SENSOR CALCULATION

	x		=		PSI (1)
INCHES OF PRODUCT		WEIGHT OF PRODUCT			
	x		=		PSI (2)
INCHES OF WATER IN TANK					
Line 1 + Line 2 = Total Positive Head Pressure In Tank			=		PSI (3)
	x		=		PSI (4)
INCHES OF WATER OUTSIDE TANK					
Total Head Pressure Minus Outside Water Pressure			=		+/- PSI (5)
Always add .5 PSI			+		PSI (6)
NOTE: If Line 6 is Less Than .5 PSI Line 7 Shall be .5 PSI					
TEST PRESSURE			=		+/- PSI (7)

ACOUSTIC TEST TIME

Equipment Calibration due date and serial numbers

	Time	Pressure	Serial Number	Calibration Due Date
Baseline Background:				
Blower Started:			In-Tank Microphone	
Test Pressure Reached:			Acoustic Signal Processor	
Blower Turned Off:			Pressure Sensor	
Test Began:			Water Sensor Display	
Test Ended:			Water Sensor Probe	

WATER SENSOR CALIBRATION

Added:	30	30	30	
	Cal #1	Cal #2	Cal #3	
Average:				
Calculation for Test Period:				
	÷ 3780 =		÷ .05	
Avg. Cal.	"A" Factor		x 60 =	
			Min. Time of Test	

Water Intrusion Test Period

Began: _____

Ended: _____

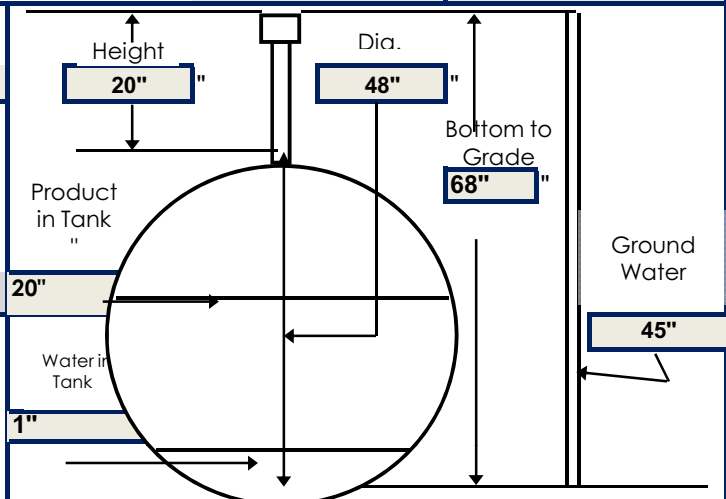

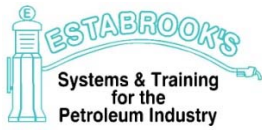

PRESSURE CALCULATION & WATER SENSOR CALIBRATION

DATA SHEET

Test Date _____

MANUFACTURED BY: ESTABROOK'S INC. 1-877-368-7215

TOTAL TANK VOL. _____

PRODUCT VOL. _____

ULLAGE VOL. _____

PRODUCT TYPE **GASOLINE**

PBS # (NEW YORK) _____

TANK # **TEST #2**

Location _____

Address _____

City/State/Zip _____

Location Contact _____

Location Phone _____

Depth of Groundwater Determined: _____

By: _____

Where: _____

PRESSURE SENSOR CALCULATION

_____	x	_____	=	_____	PSI (1)
INCHES OF PRODUCT		WEIGHT OF PRODUCT			
_____	x	_____	=	_____	PSI (2)
INCHES OF WATER IN TANK					
Line 1 + Line 2 = Total Positive Head Pressure In Tank			=	_____	PSI (3)
_____	x	_____	=	_____	PSI (4)
INCHES OF WATER OUTSIDE TANK					
Total Head Pressure Minus Outside Water Pressure			=	_____	+/-PSI (5)
Always add .5 PSI			+	_____	PSI (6)
NOTE: If Line 6 is Less Than .5 PSI Line 7 Shall be .5 PSI					
TEST PRESSURE			=	_____	+/-PSI (7)

ACOUSTIC TEST TIME

Equipment Calibration due date and serial numbers

	Time	Pressure		Serial Number	Calibration Due Date
Baseline Background:	_____	_____			
Blower Started:	_____	_____	In-Tank Microphone	_____	_____
Test Pressure Reached:	_____	_____	Acoustic Signal Processor	_____	_____
Blower Turned Off:	_____	_____	Pressure Sensor	_____	_____
Test Began:	_____	_____	Water Sensor Display	_____	_____
Test Ended:	_____	_____	Water Sensor Probe	_____	_____

WATER SENSOR CALIBRATION

Added: 0 0 0

Cal #1 Cal #2 Cal #3

Average: _____

Calculation for Test Period:

_____ ÷ 3780 = _____ ÷ .05 _____ x 60 = _____

Avg. Cal. "A" Factor Min. Time of Test

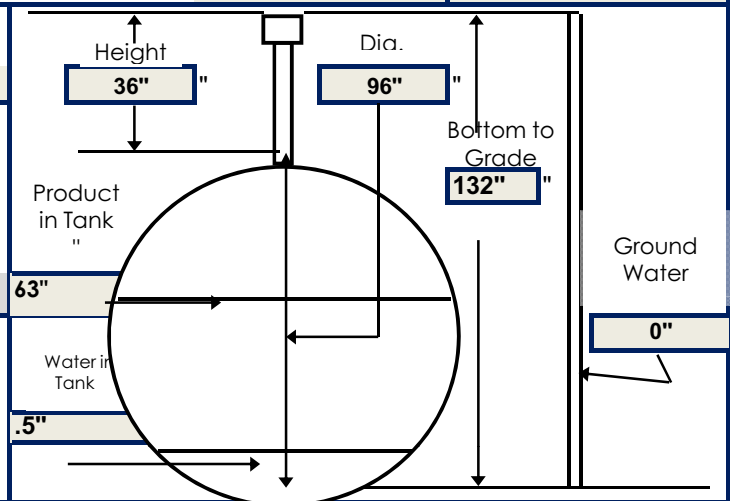

Water Intrusion Test Period

Began: _____

Ended: _____



PRESSURE CALCULATION & WATER SENSOR CALIBRATION

DATA SHEET

Test Date _____

MANUFACTURED BY: ESTABROOK'S INC. 1-877-368-7215

TOTAL TANK VOL. _____

PRODUCT VOL. _____

ULLAGE VOL. _____

PRODUCT TYPE **GASOLINE**

PBS # (NEW YORK) _____

TANK # **TEST #3**

Location _____

Address _____

City/State/Zip _____

Location Contact _____

Location Phone _____

Depth of Groundwater Determined: _____

By: _____

Where: _____

PRESSURE SENSOR CALCULATION

_____	x	_____	=	_____	PSI (1)
INCHES OF PRODUCT		WEIGHT OF PRODUCT			
_____	x	_____	=	_____	PSI (2)
INCHES OF WATER IN TANK					
Line 1 + Line 2 = Total Positive Head Pressure In Tank			=	_____	PSI (3)
_____	x	_____	=	_____	PSI (4)
INCHES OF WATER OUTSIDE TANK					
Total Head Pressure Minus Outside Water Pressure			=	_____	+/- PSI (5)
Always add .5 PSI			+	_____	PSI (6)
NOTE: If Line 6 is Less Than .5 PSI Line 7 Shall be .5 PSI					
TEST PRESSURE			=	_____	+/- PSI (7)

ACOUSTIC TEST TIME

Equipment Calibration due date and serial numbers

	Time	Pressure	Serial Number	Calibration Due Date
Baseline Background:	_____	_____		
Blower Started:	_____	_____	In-Tank Microphone	_____
Test Pressure Reached:	_____	_____	Acoustic Signal Processor	_____
Blower Turned Off:	_____	_____	Pressure Sensor	_____
Test Began:	_____	_____	Water Sensor Display	_____
Test Ended:	_____	_____	Water Sensor Probe	_____

WATER SENSOR CALIBRATION

Added: **75** **75** **75**

Cal #1 Cal #2 Cal #3

Average: _____

Calculation for Test Period:

_____ ÷ 3780 = _____ ÷ .05 _____ x 60 = _____

Avg. Cal. "A" Factor Min. Time of Test

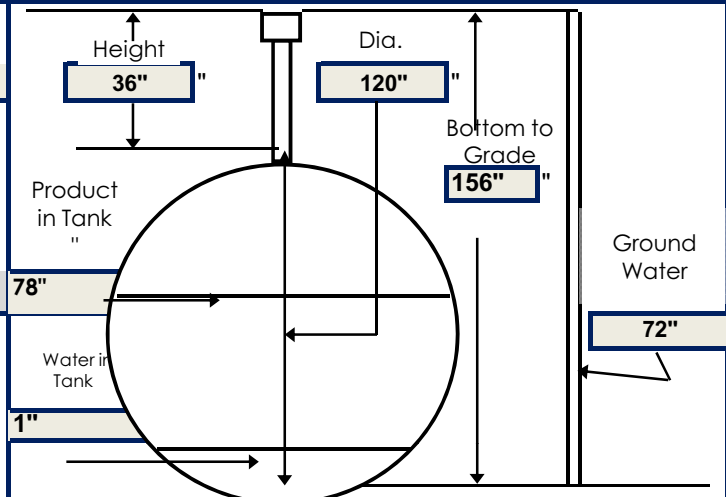

Water Intrusion Test Period

Began: _____

Ended: _____



EZY Chek Systems

PRODUCT LINE TESTER

CERTIFICATION

===== **EXAM** =====

Read each question; write the letter to the answer you chose in the space provided next to the question number.

- 1) _____ What is the gallon per line on the Estabrook's, EZY Chek Product Line Tester?
 - a. .0027
 - b. .050
 - c. .0037
 - d. .0031

- 2) _____ What is the threshold value of the Estabrook's, EZY Chek Product Line Tester?
 - a. .0027
 - b. .050
 - c. .0037
 - d. .0031

- 3) _____ How much pressure shall be applied to the pressure line?
 - a. 1 times the working pressure
 - b. 2 times the working pressure
 - c. At working pressure
 - d. 1 1/2 times the working pressure

- 4) _____ What is the "minimum" pressure applied to a suction line?
 - a. 2.5 psi
 - b. 7 psi
 - c. 10 psi
 - d. 1 psi

- 5) _____ What is the "maximum" pressure applied to a suction line?
 - a. 10 psi
 - b. 9 psi
 - c. 15 psi
 - d. 20 psi

- 6) _____ How often is data collected?
 - a. Every 15 minutes
 - b. Every 5 minutes
 - c. Once and hour
 - d. Every half hour

- 7) _____ Can a product line test be done through the filter housing?
 - a. True
 - b. False

- 8) _____ When testing through the filter housing, the shear valve must be closed?
 - a. True
 - b. False



EZY Chek Systems

PRODUCT LINE TESTER CERTIFICATION EXAM

Read each question; write the letter to the answer you chose in the space provided next to the question number.

- 9) _____ Can the test cylinder be filled through the filter housing or the shear valve?
a. True
b. False
- 10) _____ It's best to do a line test on the dispenser closest to the pump?
a. True
b. False
- 11) _____ Before continuous pressure is applied on the line; you must do the bleed back process?
a. True
b. False
- 12) _____ Once the technician collects the required half hour worth of data, and it meets stop test criteria, pass or fail, the test is completed?
a. True
b. False
- 13) _____ Once data collection starts, the minimum "3" readings must be within .040 of each other?
a. True
b. False
- 14) _____ When testing a fiberglass or steel line, the volume can not exceed 101 gallons?
a. True
b. False
- 15) _____ When testing a flex line, the volume shall be no larger than 101 gallons?
a. True
b. False
- 16) _____ One way to isolate the line from the tank is to screw the functional element down?
a. True
b. False
- 17) _____ If there is no ball valve and the functional element won't close, a line test can not be performed?
a. True
b. False
- 18) _____ When testing at the submersible pump through the leak detector port, using the Estabrook's EZY Chek Systems ISO plug, pressure can be applied through the plug to the dispenser?
a. True
b. False

Complete the data calculations and indicate a pass or fail or result



EZY CHEK SYSTEMS
PRODUCT LINE TESTER
DATA SHEET

TEST DATE _____

Testing Company Information

Name	_____
Address	_____
City	_____
Phone	_____

Test Location Information

Name	_____
Address	_____
City	_____
Phone	_____
Contact	_____

Technician Information

Name	_____
Cert #	_____

Applied Pressure _____

#1	Product Type:		_____	_____	_____
TIME	DATA	-/+	GPL	RES	GPH
9:00	78	0	0.0037	0.0000	0.0000
9:15	76		0.0037		
9:30	75		0.0037		
9:45	74		0.0037		
10:00			0.0037		
			0.0037		

FINAL RESULT: _____

#2	Product Type:		_____	_____	_____
TIME	DATA	-/+	GPL	RES	GPH
10:15	89	0	0.0037	0.0000	0.0000
10:30	88		0.0037		
10:45	87		0.0037		
11:00	87		0.0037		
11:15	86		0.0037		
			0.0037		

FINAL RESULT: _____

#3	Product Type:		_____	_____	_____
TIME	DATA	-/+	GPL	RES	GPH
1:30	84	0	0.0037	0.0000	0.0000
1:45	81		0.0037		
2:00	78		0.0037		
2:15	76		0.0037		
2:30	73		0.0037		
			0.0037		

FINAL RESULT: _____

#4	Product Type:		_____	_____	_____
TIME	DATA	-/+	GPL	RES	GPH
5:00	91	0	0.0037	0.0000	0.0000
5:15	87		0.0037		
5:30	83		0.0037		
5:45	79		0.0037		
			0.0037		
			0.0037		

FINAL RESULT: _____

#5	Product Type:		_____	_____	_____
TIME	DATA	-/+	GPL	RES	GPH
12:00	89	0	0.0037	0.0000	0.0000
12:15	88		0.0037		
12:30	88		0.0037		
			0.0037		
			0.0037		
			0.0037		

FINAL RESULT: _____

#6	Product Type:		_____	_____	_____
TIME	DATA	-/+	GPL	RES	GPH
3:00	90	0	0.0037	0.0000	0.0000
3:15	86		0.0037		
3:30	83		0.0037		
3:45	81		0.0037		
4:00	79		0.0037		
4:15	79		0.0037		

FINAL RESULT: _____



EZY Chek Systems

LEAK DETECTOR TESTER

CERTIFICATION

===== **EXAM** =====

Read each question; write the letter to the answer you chose in the space provided next to the question number.

- 1) _____ A 3 gallon per hour leak rate is equivalent to how many mL in one minute?
 - a. 1000 mL
 - b. 50mL
 - c. 189mL
 - d. 50mL

- 2) _____ Estabrook leak detector testers should be periodically tested for proper calibration; by maintaining line pressure at 10 psi (using a bleed off valve), inducing a leak through each jet valve (one at a time) and measuring .05 gallons/min (equivalent to 189 mL/min & 3 gph) in a calibrated burette. If the jet valve produces .05 gallons or 189 mL in one minute, the jet is inducing the proper leak rate on the piping system?
 - a. True
 - b. False

- 3) _____ When conducting a 3 gph functionality test of an electronic LLD, only one jet valve shall be left open (2 closed) to simulate a leak into an approved container. The electronic LLD only passes if it detects the leak and signals an alarm with the leak induced on the line?
 - a. True
 - b. False

- 4) _____ Line pressure shall always be reduced to 1 psi or less prior to conducting a functionality test of a mechanical LLD
 - a. True
 - b. False

- 5) _____ FePetro and Red Jacket (Veeder Root) mechanical LLD's go into their leak sensing position at about 10-14 psi?
 - a. True
 - b. False

- 6) _____ Vaporless Manufactured mechanical LLD's go into their leak sensing position at about 18-20 psi?
 - a. True
 - b. False

- 8) _____ After failing an existing mechanical LLD and installing a brand new mechanical LLD in the submersible transfer pump; there is no need to test the new leak detector for proper operation because they never fail "out-of-the-box."?
 - a. True
 - b. False

- 9) _____ When hooking up test equipment at the dispenser shear valve when installing a new mechanical LLD; proper lockout/tag-out procedure shall always be followed to prevent personal injury and environmental damage due to a submersible pump being accidentally turned on while work is being conducted?
 - a. True
 - b. False

- 10) _____ A technician shall always check to see that no leaks are present after removing his test equipment and putting the system back into full operation?
 - a. True
 - b. False